

REQUIREMENTS FOR SILT FENCE:

FENCE POSTS SHALL BE SPACED 8 FEET CENTER-TO-CENTER OR CLOSER. THEY SHALL EXTEND AT LEAST 2 FEET INTO THE GROUND AND EXTEND AT LEAST 2 FEET ABOVE GROUND (FIG. 23-2). POSTS SHALL BE CONSTRUCTED OF HARDWOOD WITH A MINIMUM DIAMETER THICKNESS OF 1 1/2 INCHES.

'SUPER' SILT FENCE - A METAL FENCE WITH 6 INCH OR SMALLER MESH OPENINGS AND AT LEAST 2 FEET HIGH MAY BE UTILIZED. FASTENED TO THE FENCE POSTS, TO PROVIDE REINFORCEMENT AND SUPPORT TO THE GEOTEXTILE FABRIC. POSTS MAY BE SPACED LESS THAN 8 FEET ON CENTER AND MAY BE CONSTRUCTED OF HEAVIER WOOD OR METAL AS NEEDED TO WITHSTAND HEAVY SEDIMENT LOADING. THIS PRACTICE IS APPROPRIATE WHERE SPACE FOR OTHER PRACTICES IS LIMITED AND HEAVY SEDIMENT LOADING IS EXPECTED. 'SUPER' SILT FENCE IS NOT TO BE USED IN PLACE OF PROPERLY DESIGNED DIVERSIONS (PG. 15-1) WHICH MAY BE NEEDED TO CONTROL SURFACE RUNOFF RATES AND VELOCITIES.

A GEOTEXTILE FABRIC, RECOMMENDED FOR SUCH USE BY THE MANUFACTURER, SHALL BE BURIED AT LEAST 6 INCHES DEEP IN THE GROUND. THE FABRIC SHALL EXTEND AT LEAST 2 FEET ABOVE THE GROUND. THE FABRIC MUST BE SECURELY FASTENED TO THE POSTS USING A SYSTEM CONSISTING OF METAL FASTENERS (NAILS OR STAPLES) AND A HIGH STRENGTH REINFORCEMENT MATERIAL (NYLON WEBBING, GROMMETS, WASHERS ETC.) PLACED BETWEEN THE FASTENER AND THE GEOTEXTILE FABRIC. THE FASTENING SYSTEM SHALL RESIST TEARING AWAY FROM THE POST. THE FABRIC SHALL INCORPORATE A DRAWSTRING IN THE TOP PORTION OF THE FENCE FOR ADDED STRENGTH.

SILT FENCE DETAIL
NO SCALE

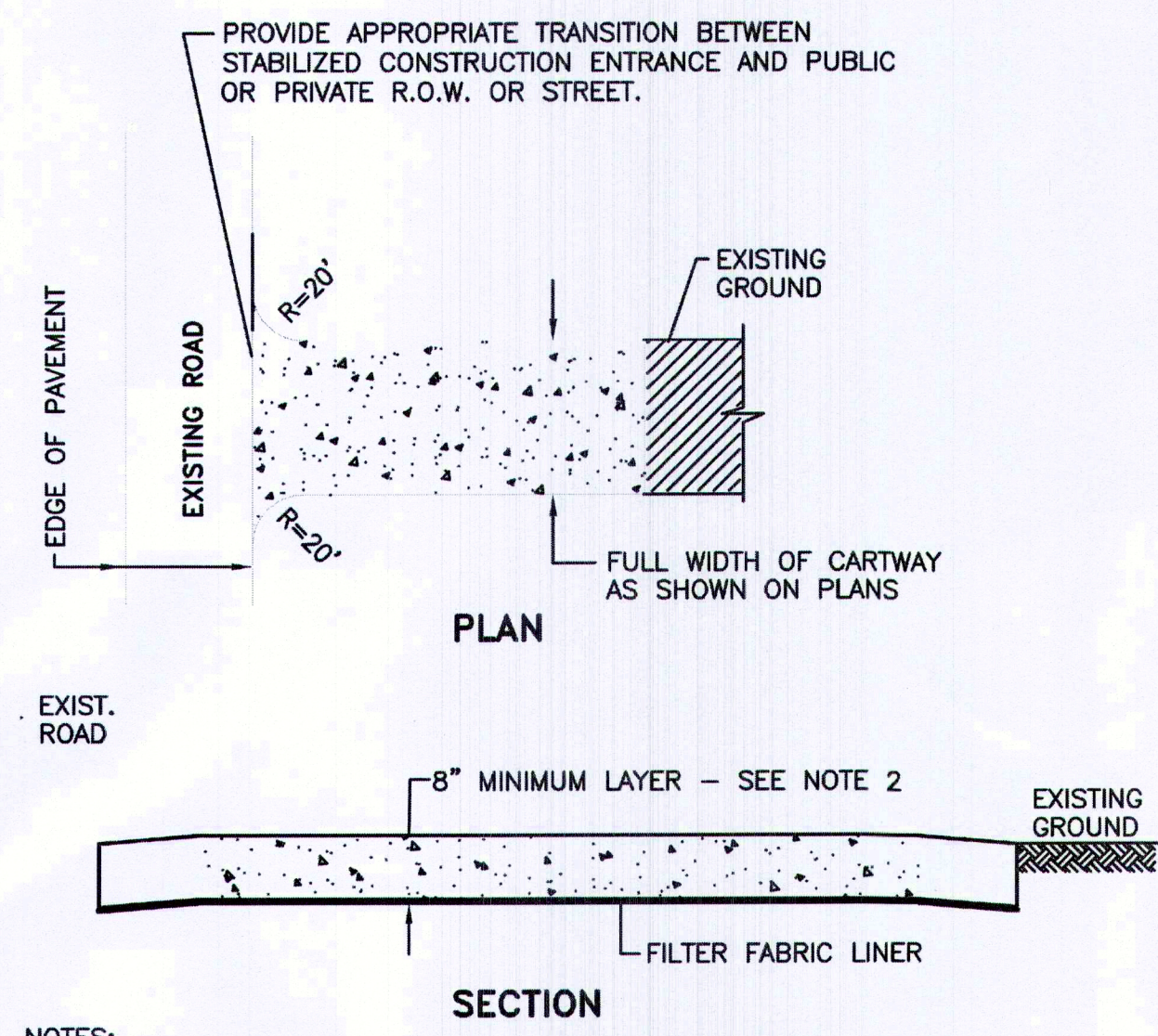

- NOTES:**
1. PLACE STABILIZED CONSTRUCTION ENTRANCE AT LOCATION
 2. STONE SIZE SHALL BE ASTM C-33, SIZE NO. 2 OR 3, CLEANED CRUSHED ANGULAR STONE.
 3. THE THICKNESS OF THE STABILIZED CONSTRUCTION ENTRANCE SHALL NOT BE LESS THAN 8".
 4. WIDTH - NOT LESS THAN FULL WIDTH OF POINTS OF INGRESS OR EGRESS.
 5. THE STABILIZED CONSTRUCTION ENTRANCE SHALL BE MAINTAINED IN A CONDITION WHICH WILL PREVENT TRACKING OR FLOWING OF SEDIMENT ONTO THE R.O.W./PAVEMENT. THIS REQUIRES PERIODIC TOP DRESSING WITH ADDITIONAL STONE OR ADDITIONAL LENGTH AS CONDITIONS DEMAND AND REPAIR AND/OR CLEANOUT OF ANY MEASURE USED TO TRAP SEDIMENT.
 6. ALL SEDIMENT SPILLED, DROPPED, WASHED OR TRACKED ONTO THE PUBLIC ROADWAY MUST BE REMOVED IMMEDIATELY.

TRACKING PAD DETAIL
NO SCALE

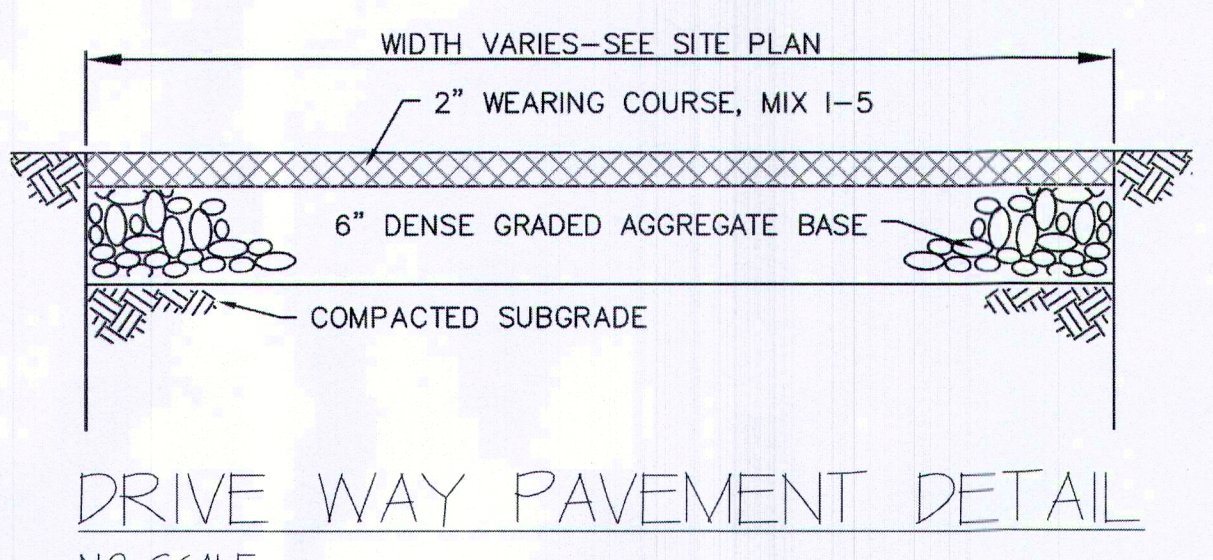

DRIVE WAY PAVEMENT DETAIL
NO SCALE

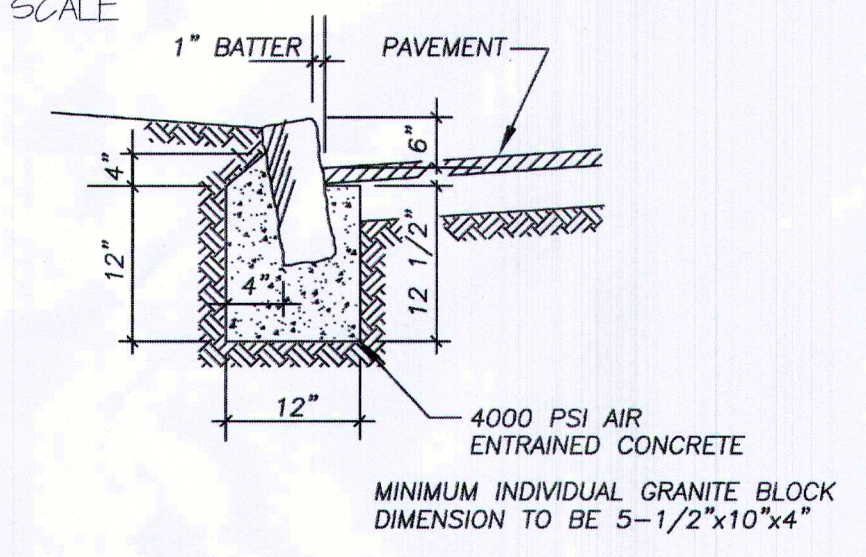

GRANITE CURB DETAIL
NO SCALE

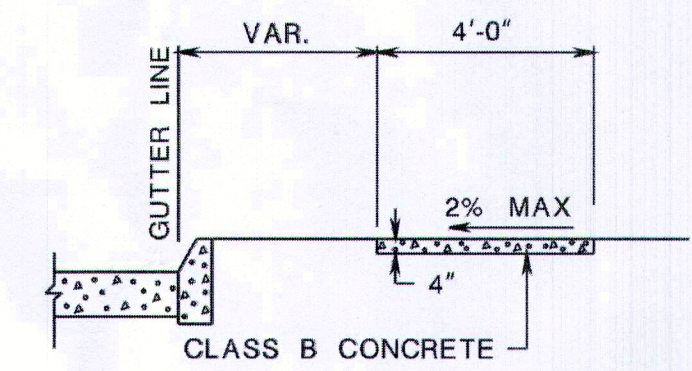

CONCRETE SIDE WALK DETAIL
NO SCALE

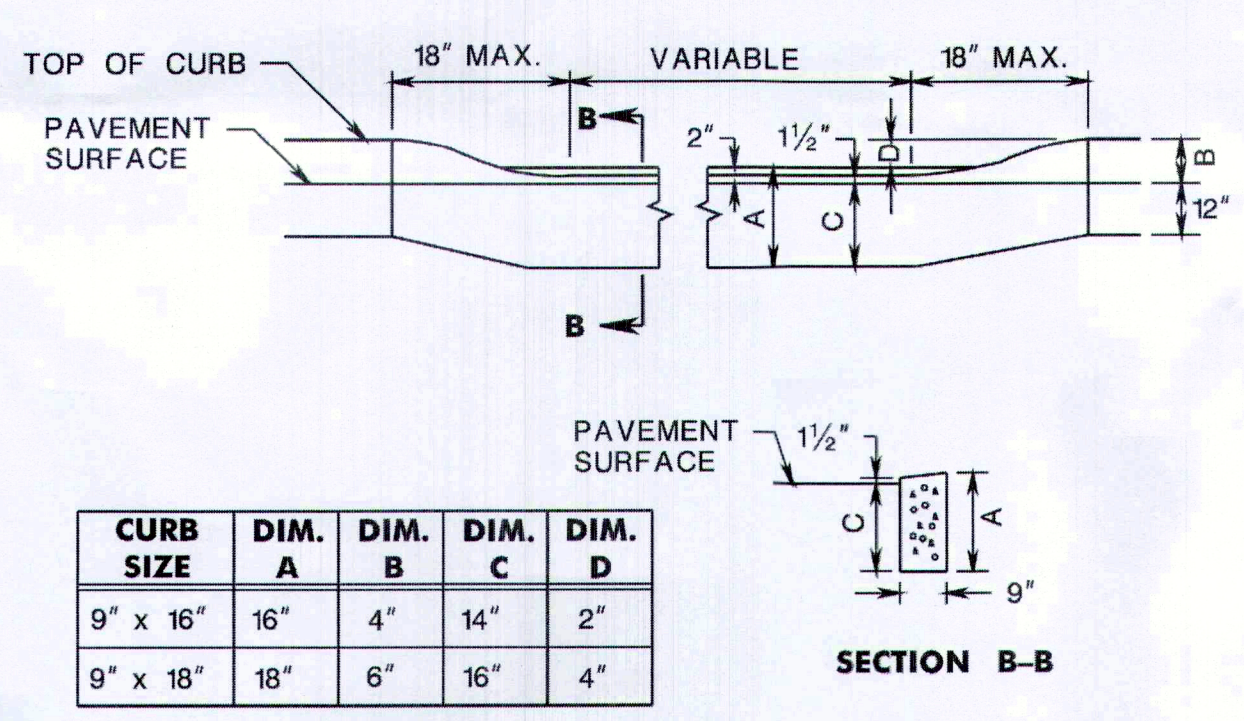

CURB DEPRESSION DETAIL AT DRIVE WAY
NO SCALE

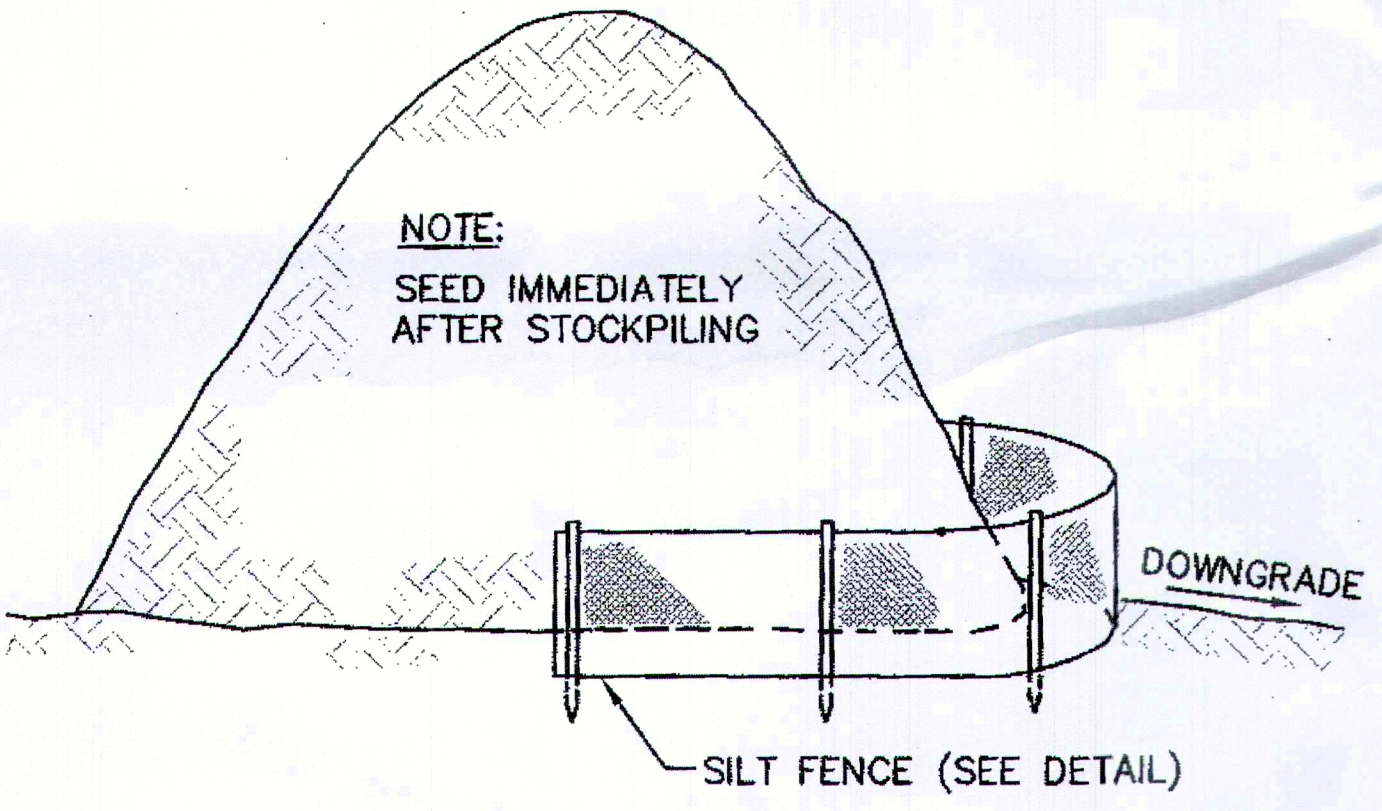

SOIL STOCK PILE DETAIL
NO SCALE

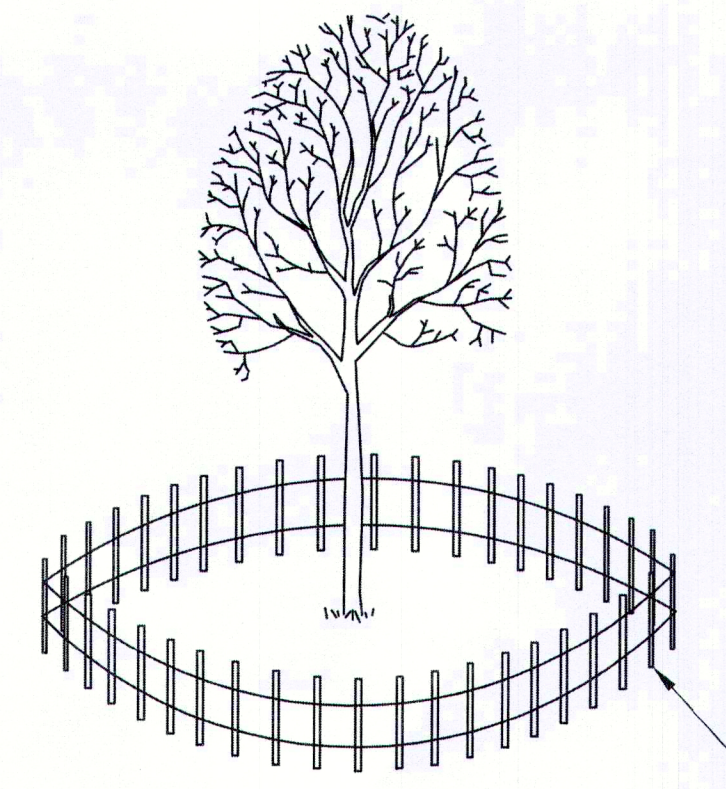

TREE PROTECTION DETAIL

- TREE PROTECTION NOTES:**
1. SNOW FENCING SHOULD BE INSTALLED AT DRIP LINE OF TREE BRANCHES.
 2. NO BOARDS ARE TO BE NAILED TO TREES.
 3. FEEDER ROOTS SHOULD NOT BE CUT INSIDE THE TREE BRANCHES DRIP LINE.
 4. TREE LIMB REMOVAL, WHERE NECESSARY, WILL BE DONE TO TRUNK OR MAIN BRANCH.
 5. ALL TREES INSIDE THE LIMIT OF DISTURBANCE TO BE PRESERVED MUST BE PROTECTED WITH ORANGE TREE PROTECTION FENCE.
 6. PROTECT TREE DRIP LINE ORANGE AREA. ANY CHANGE MUST BE FORWARDED (PRIOR TO WORK BEING COMPLETED) TO THE TOWNSHIP FORESTER FOR APPROVAL.

TREE PROTECTION DETAIL
NO SCALE

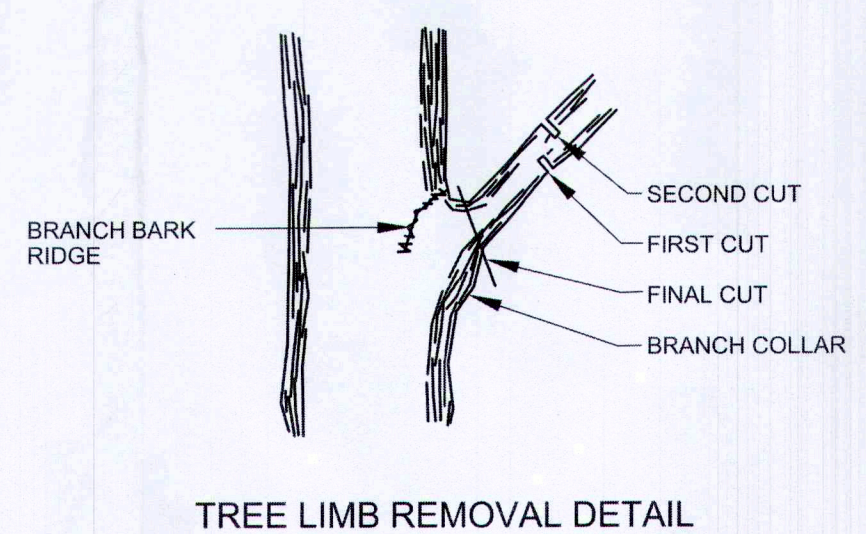

TREE LIMB REMOVAL DETAIL

INLET PROTECTION
NO SCALE

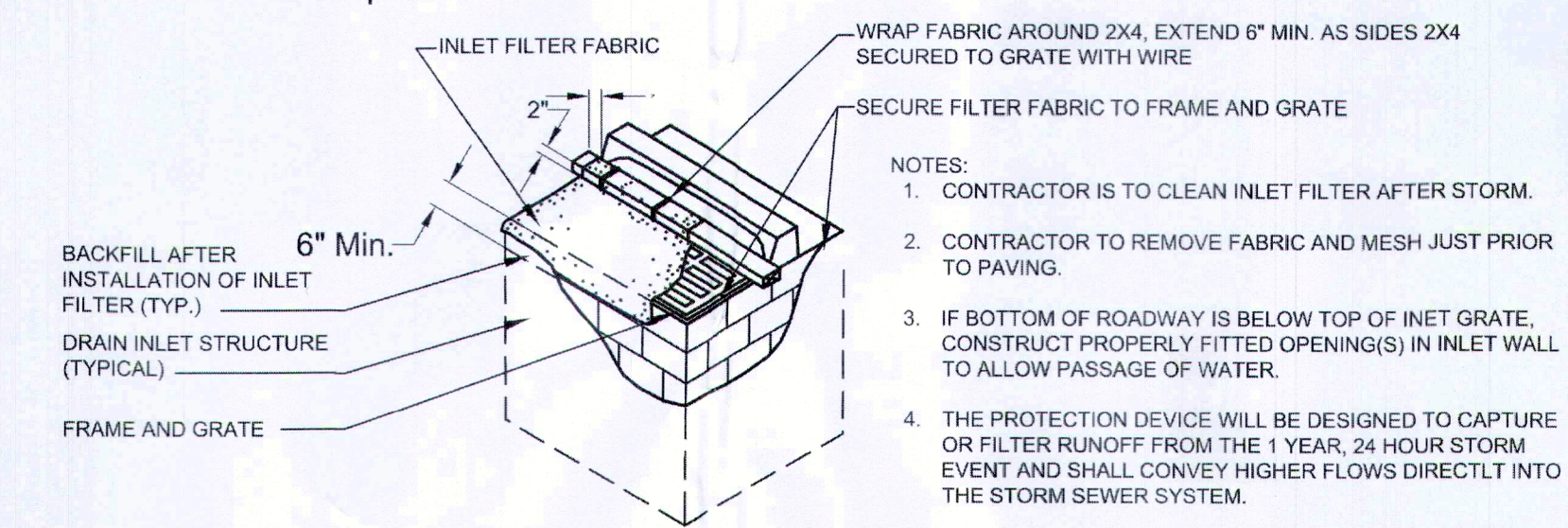

- NOTES:**
1. CONTRACTOR IS TO CLEAN INLET FILTER AFTER STORM.
 2. CONTRACTOR TO REMOVE FABRIC AND MESH JUST PRIOR TO PAVING.
 3. IF BOTTOM OF ROADWAY IS BELOW TOP OF INLET GRATE, CONSTRUCT PROPERLY FITTED OPENING(S) IN INLET WALL TO ALLOW PASSAGE OF WATER.
 4. THE PROTECTION DEVICE WILL BE DESIGNED TO CAPTURE OR FILTER RUNOFF FROM THE 1 YEAR, 24 HOUR STORM EVENT AND SHALL CONVEY HIGHER FLOWS DIRECTLY INTO THE STORM SEWER SYSTEM.

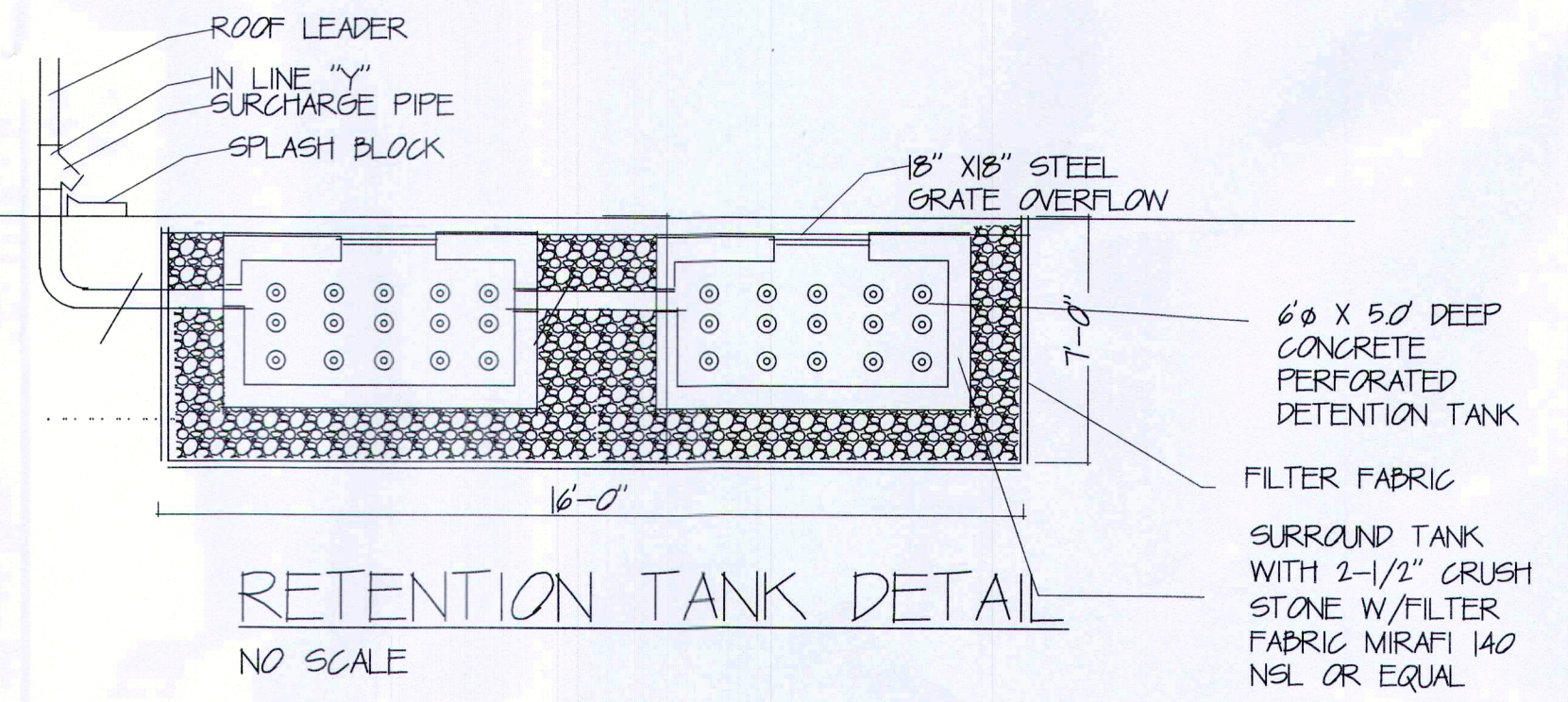

RETENTION TANK DETAIL
NO SCALE

TEMPORARY VEGETATIVE STABILIZATION GRASSES.
SEEDING RATES, DATES AND DEPTHS

SEED SELECTIONS	SEEDING RATE (1)		OPTIMUM SEEDING DATE (2)			OPTIMUM SEEDING DEPTH (3)
	(pounds)		based on Plant Hardiness Zone			
	Per Acre	Per 1000 Sq. Ft.	ZONE 5b, 6s	ZONE 6b	ZONE 7a, 7b	(inches)
COOL SEASON GRASSES						
PERENNIAL RYEGRASS	40	1.0	3/15-6/1 8/1-9/15	3/15-5/15 8/15-10/1	2/15-5/1 8/15-10/15	0.5
SPRING OATS	86	2.0	3/15-5/1 8/1-9/15	3/15-5/15 8/15-10/1	2/15-5/1 8/15-10/15	1.0
WINTER BARLEY	96	2.2	8/1-9/15	8/15-10/1	8/15-10/15	1.0
WINTER CEREAL RYE	112	2.8	8/1-11/1	8/1-11/15	8/1-12/15	1.0
WARM SEASON GRASSES						
PEARL MILLET	20	0.5	6/1-8/1	5/15-8/15	5/1-9/1	1.0
MILLET (GERMAN OR HUNGARIAN)	30	0.7	6/1-8/1	5/15-8/15	5/1-9/1	1.0
WEEPING LOVEGRASS	5	0.2	6/1-8/1	5/15-8/15	5/1-9/1	0.25

PERMANENT VEGETATIVE COVER

APPLICATION	SEED SELECTIONS	SEEDING RATE (pounds/Acre)	LIMESTONE (tons/Acre)	FERTILIZER (lbs/Acre)	OPTIMUM SEEDING DATES
RESIDENTIAL/COMMERCIAL LOTS	TURF TYPE TALL FESCUE	150	2	50 10-20-10	3/1-4/30 & 8/15-11/15
DRAINAGE DITCHES	REED CANARY GRASS	25			
SWALES AND DETENTION BASINS	KENTUCKY BLUEGRASS	60	2	50 10-20-10	3/1-4/30 & 8/15-11/15

1. SEEDING RATE FOR WARM GRASS, SELECTION 5-7 SHALL BE ADJUSTED TO REFLECT THE AMOUNT OF PURE LINE SEED (PLS) AS DETERMINED BY A GERMINATION TEST RESULT. NO ADJUSTMENT IS REQUIRED FOR COOL SEASON GRASSES
2. MAY BE PLANTED THROUGHOUT SUMMER, IF SOIL MOISTURE IS ADEQUATE OR SEEDED AREA CAN BE IRRIGATED
3. TWICE THE DEPTH FOR SANDY SOILS

RETENTION TANK CALCULATIONS

-STORE 9" OF RUNOFF FROM NEW IMPERVIOUS AREA: 1463 SF

-STORAGE VOL. REQUIRED = 1463 SF X 3/8" = 365 CU. FT.

-TYPICAL DRYWELL: 8' X 8' X 6' DEEP STONE BED W/ 5' X 5' DEEP PRECAST CONC. SEEPAGE TANKS -DISPLACEMENT VOL. OF SEEPAGE TANK:

$\Pi \times r^2 \times h = \Pi \times (2.5)^2 \times 5 = 98 \text{ CU. FT.}$

-STORAGE VOL. OF SEEPAGE TANKS: $\Pi \times r^2 \times h = \Pi \times (2.25)^2 \times 4.5 = 71.5 \text{ CU. FT.}$

-VOL. OF BED: 8' X 8' X 6" = 384 CU. FT.

-STORAGE VOL. OF BED: (VOL. STONE - DISP. VOL. OF TANK) X 4

VOIDS = 384 - 98 X 4 = 114

STORAGE VOL. OF DRYWELL: BED VOL. + TANK VOL. = 114 + 71.5 = 185.5 CU. FT.

(2) 5' X 5' DEEP PRECAST CONCRETE SEEPAGE TANK IN 16' X 8' X 6' DEEP STONE BED. 365 > 372 OK

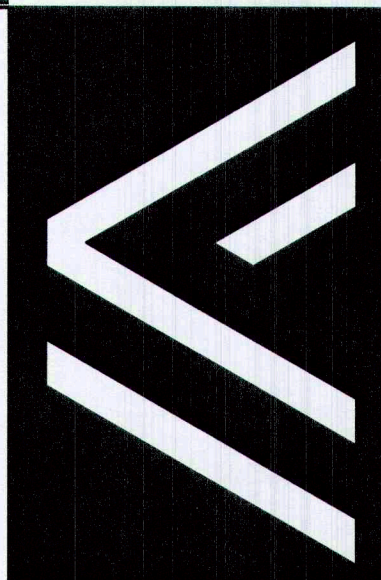

MISO ASSOC., P.A. ARCHITECTS
211 WASHINGTON CORNER ROAD
BERNARDSVILLE, NJ
973-768-1333
MISOARCHITECT@YAHOO.COM

V.C. MISO	RA	PA	RA	RA	RA	RA
A07846	PA	PA	PA	PA	PA	PA
018332-1	NY	NY	NY	NY	NY	NY
010024	IL	IL	IL	IL	IL	IL
11810-8	PA	PA	PA	PA	PA	PA
NCARB 37,079	NCARB	NCARB	NCARB	NCARB	NCARB	NCARB

12-20-22
12-20-23
2-01-24

PROPOSED ADDITION AND ALTERATION FOR:
MR. AND MRS. S. MARSCOVERTA
45 MONTROSE AVE
VERONA, NJ

DATE	6-01-21
JOB NUMBER	15-41
DRAWN	CM
CHECK	
SHEET	